



# PJB P-1 BASS INSTRUMENT PRE AMPLIFIER



## OWNER'S MANUAL

# CONTENTS

<b>Read This First</b> .....	<b>Page 2</b>
<b>Overview of the P-1</b> .....	<b>Page 3</b>
<b>Front &amp; Back Panel Overview</b> .....	<b>Page 4</b>
<b>SETTING UP EQ</b> .....	<b>Page 8</b>
<b>SETTING UP LIMITER</b> .....	<b>Page 10</b>
<b>Transporting &amp; Storing the P-1</b> .....	<b>Page 10</b>
<b>Specifications</b> .....	<b>Page 11</b>
<b>Simplified Schematic</b> .....	<b>Page 12</b>
<b>Service/Warranty Information</b> .....	<b>Page 13</b>

**Thank you for purchasing the P-1. A great deal of dedication and passion went into designing and building this no-compromise, high performance pre-amplifier. It was conceived to be a dedicated pre-amplifier for the connoisseur bassist. Reading this manual will enable you to get the best performance from it and it will give you many years of service.**

### **READ THIS FIRST**

- **Before using the P-1 please read ALL the instructions.**
- **On receipt of product, check for any signs of physical damage arising from shipping. If any damage is visible contact your dealer.**
- **Keep all original packing.**
- **Never use this product in the vicinity of water. If the P-1 were to get wet, it could kill you by electrocution.**
- **Do not locate this pre-amplifier near any heat source.**
- **This pre-amplifier must be connected only to a power source specified in this manual.**
- **For safety do not leave the amplifier plugged into a power source for long periods of time when not in use.**
- **Do not let any liquid or foreign objects fall into any openings on the amplifier.**
- **Never use this pre-amplifier if it has:**
  1. **Suffered any physical damage.**
  2. **Been subjected to any liquids, rain or moisture.**
  3. **Has damaged cables connected to it.**

**If any of the above occurs, the unit should be examined by qualified service personnel.**
- **Always operate this pre-amplifier with the correctly rated fuse.**
- **Never use this unit without proper grounding.**

## **OVERVIEW THE P-1 PRE-AMPLIFIER**

The P-1 is a 19-inch 1U high rack-mount pre amplifier dedicated for use with bass instruments, either in live sound or recording applications. The sound quality is as good as or better than many so called high-end audio pre amplifiers used in expensive Hi-Fi systems or studio monitor systems. It was designed from the ground up to take on the hard work any serious musician will subject it to. It is built from the finest of materials, some of which may not be obvious to the eye like the 2% lead free silver solder connections that will never fail due to oxidization or old age. (Silver solder lasts longer and can actually improve the sound due to lower contact resistance.)

Also inside is a massive regulated power supply over powered and engineered to ensure the absolute greatest dynamic range available. Component choice and placing has been extensive in the development of this pre amplifier so as to reduce the noise floor to an almost impossible lowest level. There is no quieter pre amplifier in the bass world that we know of. The heavy-duty chassis is built to provide total ruggedness and protection and with care this unit will last a lifetime.

## **SOUND OF THE P-1**

Our design goal of the P-1 was to make it totally transparent in sound and have absolute silence between notes. When the EQ circuits are not engaged or set to be “flat”, the P-1 will give an exact representation of your instrument at the input. In other words the P-1 is a flat response pre amplifier. Many other brand pre amps do not do this and often have a large mid range depression so even when the controls may read “flat” on the front panel, it is not.

We think that the front panel should give you an exact true reading of how much or little you are changing the sound of your bass. If you boost 6dB at 40Hz, it is precisely that, the P-1 is accurately calibrated beyond any other pre amp on the market.

## FRONT AND BACK PANEL OVERVIEW

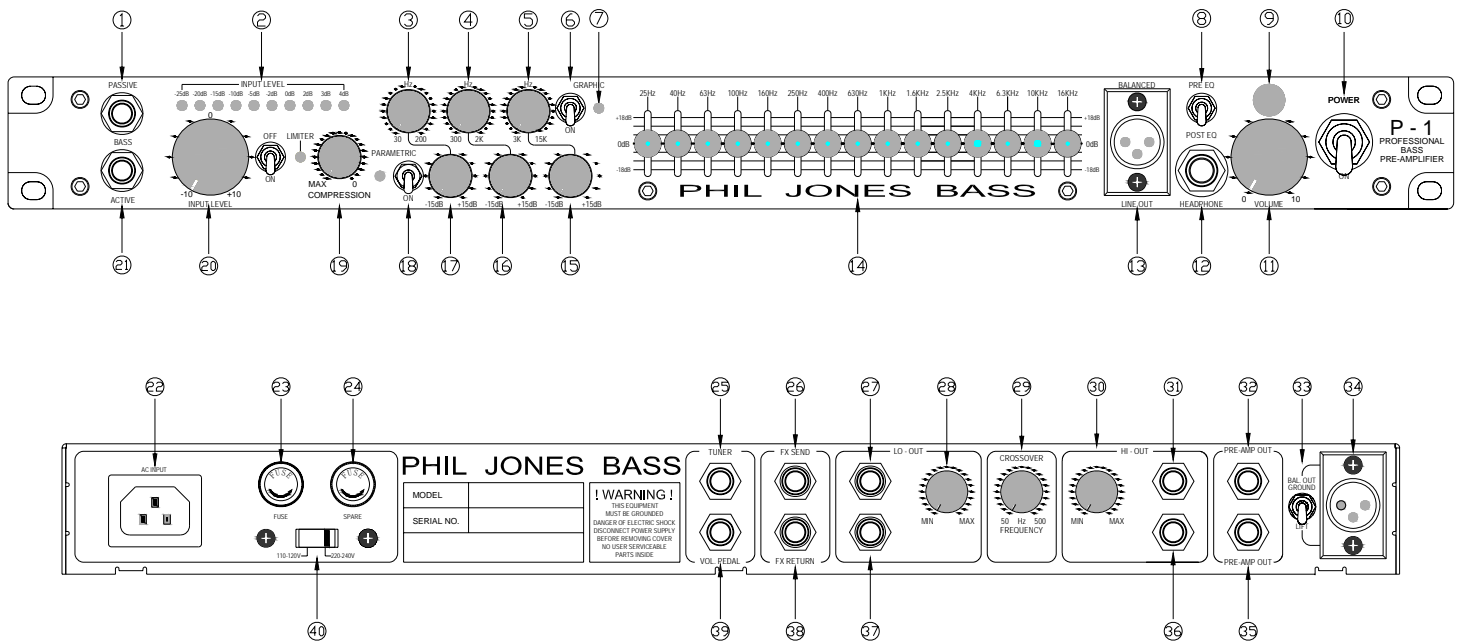

### 1. PASSIVE BASS INSTRUMENT INPUT JACK.

High sensitivity input (160mV). For bass instruments featuring non-active electronics. Especially suited for older ‘vintage’ basses. This input jack is precisely matched to high impedance pickups enabling them to faithfully reproduce the true frequency and dynamic range of the instrument.

### 2. INPUT LEVEL INDICATOR.

The 10 segment LED will light up accordingly to the amount of input applied to the amplifier and therefore gives you the best signal to noise ratio and dynamic range. From -25dB to -2dB the blue LED s will light up. It is recommended that you adjust the input signal that these will constantly light up and occasionally the green at 0dB and rarely the 2 yellow ones light up. The Red LED signals an overload condition at the input stage so you will need to back off on the input level either from your instrument or with the input level attenuator.

### 3. VARIABLE FREQUENCY 30-200Hz PARAMETRIC.

Select frequency from 30 to 200Hz.

### 4. VARIABLE FREQUENCY 300Hz-2KHz PARAMETRIC.

Select frequency from 300Hz to 2KHz.

### 5. VARIABLE FREQUENCY 3KHz-15KHz PARAMETRIC.

Select frequency from 3KHz to 15KHz.

## **6. GRAPHIC EQ ON/OFF SWITCH.**

You can switch in or bypass the graphic equalizer circuit with this.

## **7. GRAPHIC EQ ON INDICATOR.**

This will light up blue when you are going through the EQ.

## **8. XLR- DIRECT OUTPUT PRE/POST EQ SWITCH.**

This switch allows you to use the P-1 EQ or bypass EQ to suit requirements of recording or sound reinforcement application. This switch controls output of front and rear panel XLR direct outputs.

## **9. POWER ON/OFF LAMP.**

This high power LED will illuminate blue when the power is switched on.

## **10. POWER ON/OFF SWITCH.**

This switches the main power on and off in the pre amplifier.

## **11. MASTER VOLUME CONTROL.**

This is the master volume control and it controls how much power you send to your power amplifier. When setting up your tone or plugging in your instrument, you should keep this control at a low level to avoid damaging your hearing or your speakers.

## **12. HEADPHONE OUTPUT JACK.**

This jack accepts ¼ inch stereo headphone jacks. The P-1 features a high-performance headphone amplifier. This output is optimized for standard headphone impedance of 30/40 ohms but will work on practically any type of headphones.

## **13. XLR- DIRECT OUTPUT SOCKET.**

This is an ultra-low impedance (200ohms) balanced line out for use with recording or PA mixing consoles. This output is not controlled by the master volume output control. Changing the input level control will however, vary the DI output. The P-1 has two identical XLR outputs, this one is on the front panel to make easy access for connections.

## **14. 15-BAND GRAPHIC EQUALIZER.**

This is a dedicated bass instrument equalizer designed to give you precise tone control of your instrument. It is a very powerful tone processor, which with a little understanding will give you the greatest benefit in getting the most out of your instrument and sound system.

NOTE the lowest band set at 25 Hz does not work on 4 string bass tuned to EADG because it is operating in a range lower than a four string bass.

## **15. LEVEL CONTROL 3KHz-15KHz PARAMETRIC.**

Adjusts level +/- 15dB of selected frequency.

## **16. LEVEL CONTROL 300Hz-2KHz PARAMETRIC.**

Adjusts level +/- 15dB of selected frequency.

**17. LEVEL CONTROL 30-200Hz PARAMETRIC.**

Adjusts level +/-15dB of selected frequency.

**18. PARAMETRIC EQ ON/OFF SWITCH/PARAMETRIC EQ-ON INDICATOR.**

You can switch in or bypass the parametric equalizer circuit with this. This will light up blue when you are going through the parametric EQ.

**19. COMPRESSOR**

This will vary the level the limiter threshold. The compression ratio is 3dB to 1. Adjust this to suit your playing style and output power of instrument.

This L.E.D (Light Emitting Diode) will light up when the signal is being compressed. This will vary on how hard the instrument is played and how the threshold is adjusted.

**20. INPUT LEVEL SENSITIVITY CONTROL.**

Just as no two basses are alike, the same goes for players with different styles and technique. This is a fine-tuning adjustment (+/-10dB) to get the precise match between your instrument and the P-1

**21. ACTIVE BASS INSTRUMENT INPUT JACK.**

Lower sensitivity input (300mV) for basses with onboard electronics. Input matched for low signal to noise ratio and optimum transfer function of electrical signal from modern high-end basses.

**22. IEC POWER INPUT SOCKET.**

Connects the P-1 to AC power supply. Always use a grounded plug and make sure the AC cable is more than 5A rating at 250volt AC since this will have a lower grounding resistance and therefore better signal to noise ratio.

**23. AC POWER INPUT FUSE.**

Uses fast blow 1 ¼ inch fuse. (1A for 110-240volt)

**24. SPARE FUSE HOLDER.**

This is not connected to the circuit. It simply is a spare fuse should you ever need one. If you replace the main fuse, be sure to put a backup in its place. Always use the correct current rating fuse. Always keep a backup fuse available. You never know when you may need it.

**25. TUNER OUT**

Use a standard ¼ inch jack to connect to a tuner. This output can also be used as a spare line out should you ever need it.

**26. FX SEND OUTPUT JACK.**

This jack sends the signal to an effects processing unit. It can also be used to send the signal to a tuner.

**27. CROSSOVER LOW FREQUENCY OUT.**

This is a line out delivering the band of frequencies below the set crossover position.

### **28. LOW FREQUENCY OUTPUT LEVEL**

This controls the out put level from zero to maximum output

### **29. CROSSOVER FREQUENCY CONTROL**

This control determines the dividing frequency of the internal electronic low level crossover.

It is variable from 50Hz to 500Hz and the filter slope is set at 24dB/Octave.

### **30. HIGH FREQUENCY OUTPUT LEVEL**

This controls the out put level from zero to maximum output

### **31. CROSSOVER HIGH FREQUENCY OUT.**

This is a line out delivering the band of frequencies above the set crossover position.

### **32. PRE AMPLIFIER OUTPUTS**

These are used for driving a power amplifier. The master volume controls the level out of these jack sockets. Its own "buffer" amplifier circuit isolates each output-jack. The benefit is that each output is independent from each other. Even a faulty cable connected to one will not affect the other. (Most brands use paralleled outputs to save costs.)

### **33. BALANCE LINE OUTPUT GROUND LIFT SWITCH**

Use this switch to reduce any hum that is caused by different or inadequate grounding on other equipment. The switch only controls the back XLR output.

### **34. XLR- DIRECT OUTPUT SOCKET.**

Same function as 13. This out put is same as the front panel XLR output.

### **35. PRE AMPLIFIER OUTPUTS**

These are for connections to power amplifier inputs.

### **36. DUPLICATE CROSSOVER HIGH FREQUENCY OUT.**

### **37. DUPLICATE CROSSOVER LOW FREQUENCY OUT.**

### **38. FX RETURN INPUT JACK.**

This jack accepts the signal from an effects processing unit. Plugging this jack in only will disrupt the signal path in the P-1.

### **39. EXTERNAL VOLUME CONTROL SOCKET.**

This is a feature whereas you can control the amplifier output by means of the external foot volume pedal. (Not included with this unit)

### **40. AC INPUT VOLTAGE SELECTOR SWITCH.**

Switches the amplifier to run on either 110-115volt or 220-240volt AC power. **Never try to run the amplifier on a 220-240volt supply when switched to 110-115volt. This can possibly cause major damage to the unit.**

## SETTING UP PRE EQ (PARAMETRIC)

Turn on the parametric EQ switch (18). The blue light next to it will light up. Have the 3 level controls (15-16-17) adjusted so they are all centered. Switching the EQ in and out now will have no effect. Start with adjusting the mid frequency level control (16) and mid frequency control (4). Normally you will want to cut the level back and then adjust the frequency control to suit your taste.

To set up the bass boost move the low frequency control (3) to about the nine o'clock position. Then increase or decrease on the level control (17) to adjust how much bass you need. You can then adjust the frequency control (3) to tune the kind of bass tone you prefer. The frequency control extends down to frequencies lower than a low B and can even boost basses with a low F# string. Take great care in not boosting low frequencies excessively if you have a small speaker system.

The same goes for adjusting how much treble you like by using controls (5 & 15). The frequency control (5) has a wide frequency coverage (to cover all kinds of basses including ones with 'peizo' pickups) and you will find that on some basses with magnetic pickups, the upper end of this range is beyond the output of your instrument. Many magnetic bass pickups have a frequency roll off above 4KHz! So boosting at extreme high frequencies may cause more noise than signal.

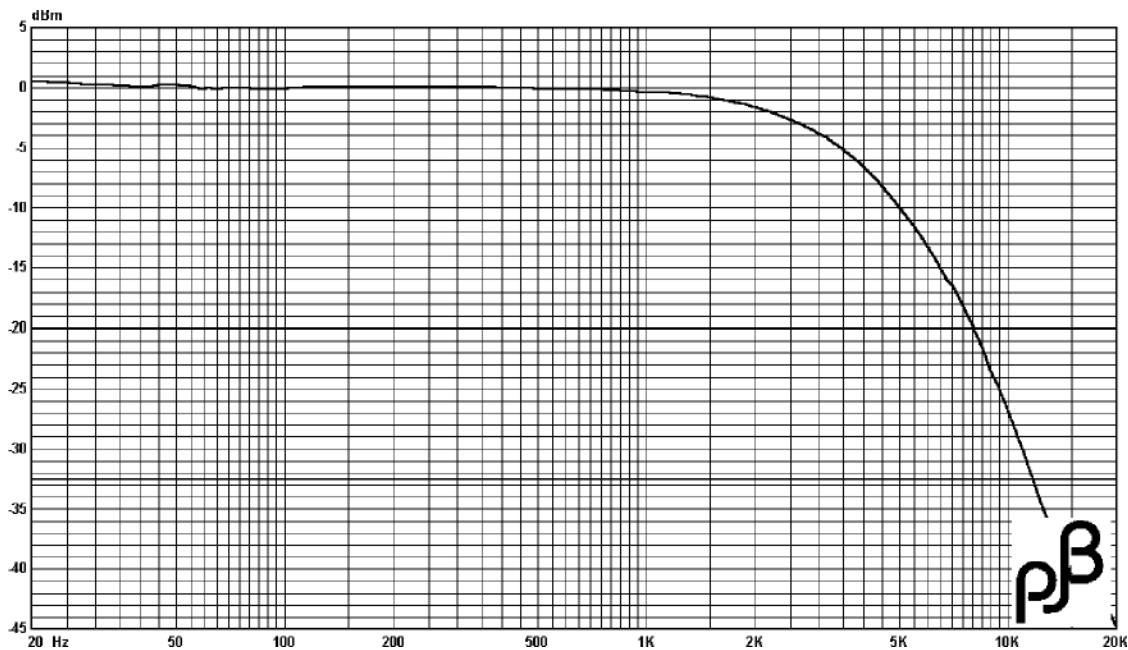

*Example of Frequency response from Pickup output of 1970 Fender Precision Bass.*

### **The Graphic EQ.**

This is a 15 band EQ that covers the full spectrum of a bass and beyond. This is used to fine-tune your bass tone to perfection. Often playing in different venues will cause your bass to sound different. This is partially due to the acoustics of the hall influencing the low frequency waves that are coming from your speaker. Bass waves are large and room dimensions heavily influence them when the walls reflect the sound waves, causing them to collide by adding together or canceling each other out. This causes some fundamental notes (the ones you feel more than hear) to ring out louder than others and some note not to be heard at all.

Here is an indication of where fundamental bass frequencies are, showing open string's approximate frequencies and acoustic wavelength.

<b>F# string</b>	<b>24Hz</b>	<b>46 feet</b>
<b>B string</b>	<b>31Hz</b>	<b>36 feet</b>
<b>E string</b>	<b>41Hz</b>	<b>27 feet</b>
<b>A string</b>	<b>55Hz</b>	<b>20 feet</b>
<b>D string</b>	<b>73Hz</b>	<b>15 feet</b>
<b>G string</b>	<b>98Hz</b>	<b>11 feet</b>
<b>C string</b>	<b>130Hz</b>	<b>9 feet</b>

This may give you some indication of the offending notes (frequencies) that may be booming or resonating louder or quieter than others. For example if your speakers are 5 feet from a wall, the open A string may sound lack of weight. That could be because the path length of the reflected sound off the wall from your speaker is exactly corresponding to half a wavelength on the open A string causing at that particular note a cancellation.

Note that the position of where you place your speakers will ultimately affect your tone. Placing a speaker with the back close to a wall will help to reinforce the lower notes. Placing the speaker in a room corner will further enhance the low notes.

Unfortunately for bass players, low frequencies are always very difficult to control with room acoustics. The reproduced wavelengths of the notes you are playing often correspond to the room dimensions, in which case the reflected sound off the walls interferes with the sound from the speaker. So the graphic EQ is by far your best weapon of choice in killing standing waves that develop in the room. From about 250Hz upwards, the graphic EQ is just controlling your overtones on the strings bearing in mind that even the 60Hz control will alter the second harmonic on an open B string.

The amount of control per frequency band is up to 36dB (+/-18dB). You should try to avoid using excessive boosting of EQ on the lower frequency ranges (25, 40, 63 and 100Hz bands) as this will reduce amplifier headroom and possibly damage your speakers, since the amplifier may force them to move beyond their physical capability. If you hear large amounts of distortion coming from your speakers when you boost the lower bands, you should immediately back off on the EQ. If you cannot get enough low-end weight for your taste, maybe you need more speakers.

If you are playing a 4 string bass, the lowest fundamental note is 41.2Hz on the open E string. It is therefore not necessary to boost the first 30Hz band on the EQ because it is set lower than the lowest note you play and it is out of range on your instrument. In fact reducing this band will considerably tighten up you bottom end and make your bass sound more punchy.

### **SETTING UP THE LIMITER**

Although a limiter is not essential to bass amplification, it can be a useful tool in smoothing out the character of your instrument or playing style. The P-1 limiter has a preset compression ratio of 3 to 1. For each additional increase of 3dB above the set threshold, the increase in level is actually 1dB. So dynamic range of your instrument is reduced.

First set up the limiter by having the compression control (5) set fully clockwise. Now switch on the limiter (4). Start playing and turn control (14) anti-clockwise. You will see the red light start to come on and that is the indication that the limiter is now working. Set this control to suit your taste.

### **TAKING CARE OF YOUR P-1**

The P-1 will give years and probably decades of reliable service if it is cared for. The P-1 was built to be as rugged as possible. However you should handle it with care. Keep it away from moisture, heat and dust. Clean with a soft damp cloth such as a moist towel. Do not use chemicals or solvents to clean it.

Many perishable PJB parts are available as replacements, such as handles, feet casters, grills, etc. These are available from your authorized PJB dealer or direct from PJB.

### **TRANSPORTING AND STORING THE P-1**

When transporting in a vehicle, it is recommended that you use an external case or heavy duty cover to prevent it being damaged by falling over or other objects falling on it.

#### **When Storing:**

- Keep the P-1 in a dry location preferably at room temperature.
- Do not store the P-1 in temperatures below -20 Degrees C or above 40 Degrees C.
- Do not allow it to get wet. If this occurs, never turn it on in this condition.

Do not leave the P-1 connected to a power source.

## SPECIFICATIONS

**Frequency Response:** 18Hz-22kHz +/-1dB

**Signal to Noise:** Better than 100dB

**Distortion:** Less than 0.01%

**Maximum Output:** 5 Volts RMS

**Input Impedance Passive:** 4.7M Ohm

**Input Impedance Active:** 100K Ohm

**XLR Balance Output Impedance:** 200 Ohms

**Parametric EQ:** +/-15 dB at 30-200Hz, 300-2kHz, and 3kHz-15kHz

**Graphic EQ:** +/-18dB at 25,40, 63, 100, 160, 250, 400, 630,1K, 1.6K, 2.5K, 4K, 6.3K, 10K and 16kHz.

**Headphone Output:** 2.8Volts RMS into 60 Ohm load per Channel

**Compressor/limiter:** 3-1 compression ratio.

**Crossover:** Variable Frequency 50-500Hz

**Crossover Filter Slope:** 24dB/Octave.

**Power Requirements:** USA, Canada & Japan 120V AC, Europe and Asia 240Volts.

**Power Consumption:** 25 watts Maximum.

**Dimensions:** 19inch Wide x 1.7 Inch High x 12.5 inch Deep.

**Weight:** 11.9 Pounds



# PJB P-1 SIMPLIFIED BLOCK SCHEMATIC

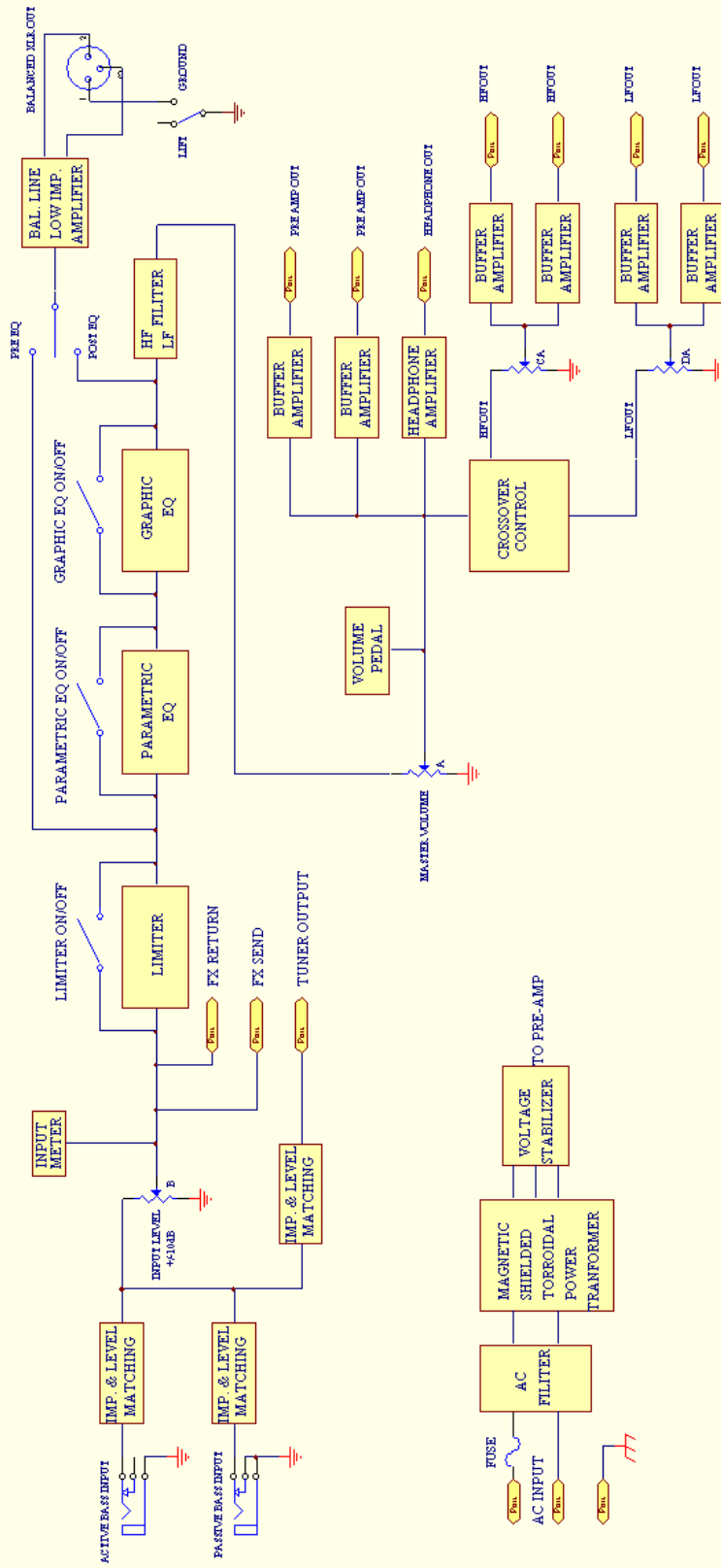

Phil Jones Bass

## **SERVICE AT A PJB SERVICE CENTER**

Your amplifier has very sophisticated circuitry, which should only be serviced by a fully trained technician. This is one reason each unit has the printed warning label on the back.

PJB customers may obtain service from an authorized PJB Sales & Service Center. It is important that you have your copy of sale as your proof of purchase. Simply present you bill of sale along with the defective unit to an authorized PJB Service Center to obtain service. They will handle the necessary paperwork and repair. Remember to transport your amplifier in the original PJB packaging.

Should the P-1 need to be serviced, service technicians will appreciate its modular construction using multi-pin plugs and Integrated Circuit sockets. So any repairs can be done quickly with ease and speed keeping repair labor costs low.

PJB is dedicated to ongoing research on bass amplification. As a result specifications are likely to change without notice owing to our relentless pursuit of perfection. All PJB owner's manuals can be downloaded from our website in PDF files.

## **WARRANTY INFORMATION**

The P-1 has a warranty period of 5 years, starting from the date of purchase. The buyer must complete and return the enclosed warranty card within 14 days of purchase.

This warranty covers defect in materials or workmanship that occurs in normal use. Within warranty period PJB will repair or replace the defect unit free of labor and parts charge. It is the buyer's responsibility to use the amplifier strictly according to instructions written in this manual. This warranty is not transferable; it is provided to original owner only. Damage/defects caused by the following conditions are not covered by this warranty:

Improper handling, neglect or failure to operate the unit in compliance with the instructions given in user manual; Connection or operation of the amplifier in any way that does not comply with the technical or safety regulations applicable in the country where the product is used; Repairs or modifications by anyone other than authorized PJB service agent;

Damages/defects caused by force majeure or any other condition that is beyond the control of PJB. If the unit's serial number is defaced or removed.

Should you need any warranty service on the P-1, please bring it back to the dealer from whom you purchased the amplifier, along with your sales receipt. Depending on the complexity of the repair work, your dealer may return the defect unit to PJB service center for repair or replacement.

**Phil Jones Bass**  
**8559 Page Ave**  
**St. Louis, MO 63114.**  
**USA**

Tel: 314 814 3383

Fax: 314 628 9941

[www.philjonesbass.com](http://www.philjonesbass.com)

[support@philjonesbass.com](mailto:support@philjonesbass.com)